

CS844

Carbon / Sulfur by Combustion



844 Series – Carbon / Sulfur by Combustion

LECO's CS844 Series will redefine the way you determine carbon and sulfur in primary steels, ores, finished metals, and other inorganic materials. Using extensive customer feedback and innovative engineering, our latest instrumentation takes advantage of our CORNERSTONE® brand software platform, powered by a touch-screen interface to increase usability and lower the cost-per-analysis

Additional features – such as a high-efficiency combustion furnace, improved IR cell design, rugged design, and available automation – make the CS844 Series a valuable resource for any industrial environment needing accurate analysis of carbon and /or sulfur.



User-Friendly CORNERSTONE® Brand Software

The exclusive Cornerstone brand software with touch interface enables the user to have complete access to analysis control, method settings, diagnostics, reporting, and more in a highly organised and immersive environment. Designed through a collaboration of customer feedback and innovative engineering, Cornerstone allows

the user to conduct all of their day-to-day operations within a single Analysis screen designed for speed and ease-of-use. Our innovative grouping of sample data into sets and replicates simplifies the data output and automatically calculates relevant statistics, alleviating the need for additional data processing.



Software – Features and Benefits

- The CORNERSTONE® software is divided into four main sections – Analysis, Diagnostics, Settings, and Instrument – for simplified navigation and organisation
- Toolbars, sliders, and drop-down menus make it easy to set parameters for calibration and data processing
- The software also includes real-time ambient monitors, with fully animated system diagrams
- Advanced diagnostic features include a thorough digital on-board manual, maintenance animations, photo illustrations, and screen captures that quickly provide the direction needed without having to refer to multiple manuals
- Cornerstone also supports extended data archiving and flexible reporting capabilities

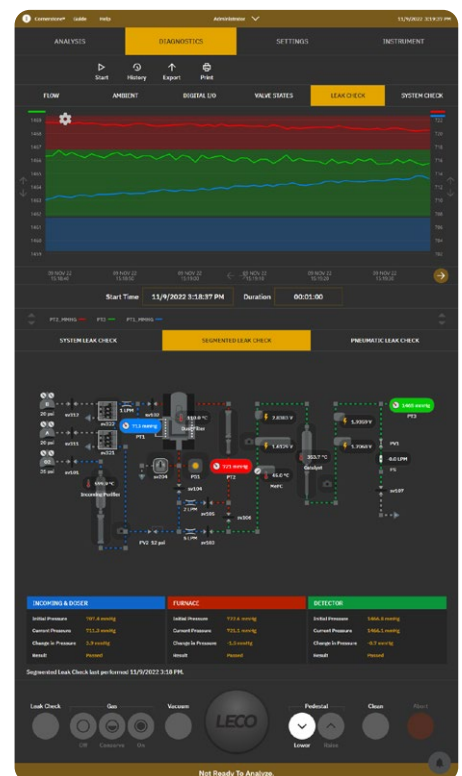
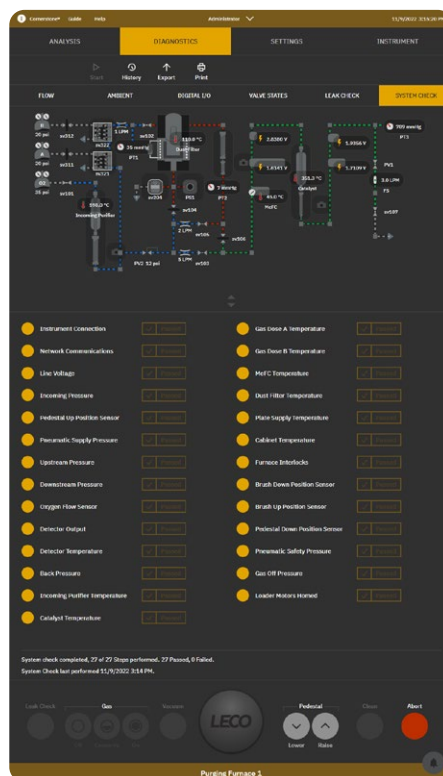
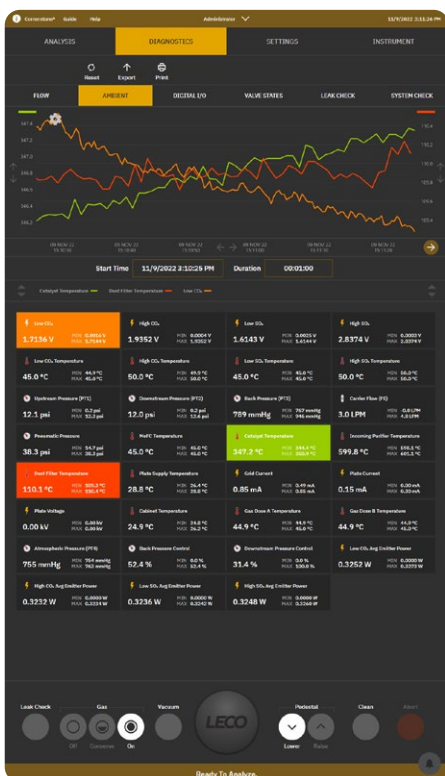
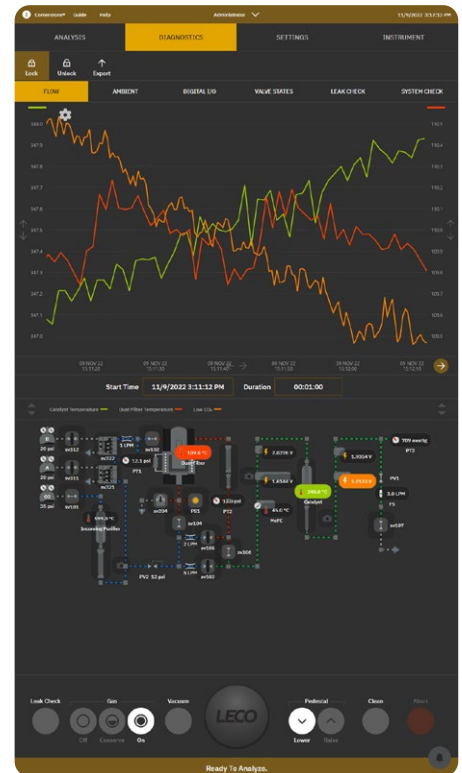
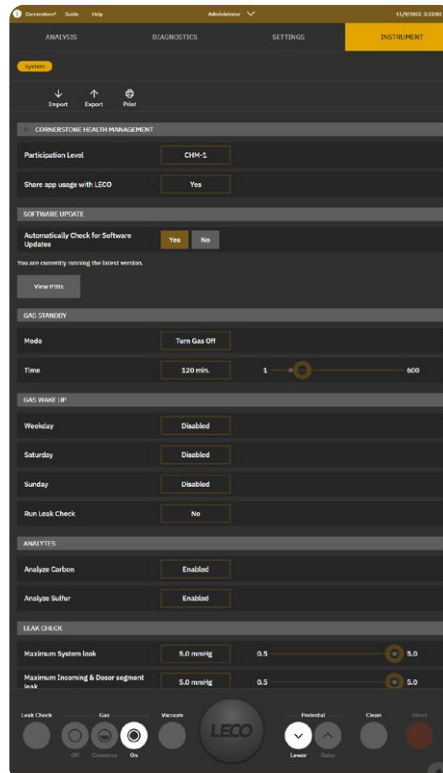

Instrument – Highlights and Features

Features and Benefits

- Fully-adjustable six-axis boom-mount improves ergonomics
- Tool-free autocleaner removal simplifies dust filter maintenance and reduces downtime
- Non-touch interface systems also available



Shown with touch-screen monitor



Shown with stand-alone touch-screen monitor



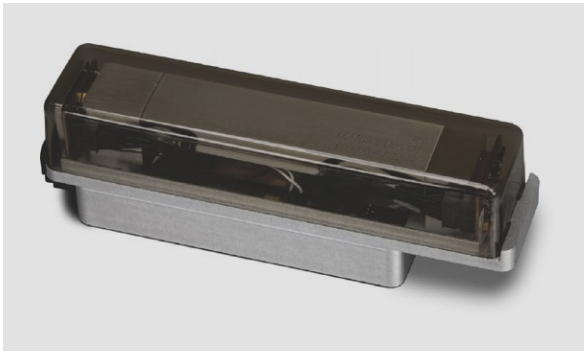

Improved IR cell design

- Thermostatic construction provides increased protection from ambient temperature fluctuations
- Optimised emitter control and detection circuitry improves the IR cell lifetime and long-term stability, resulting in superior accuracy and precision
- Dual-range detection for both carbon and sulfur

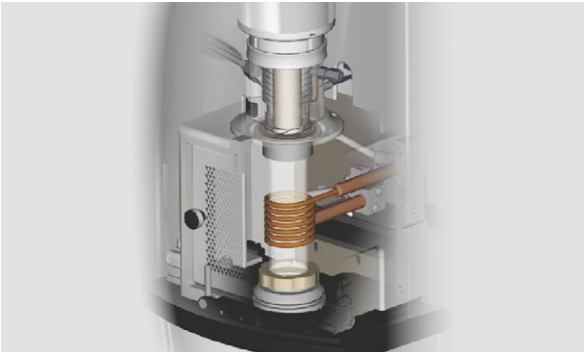

High-efficiency furnace

- Solid-state RF furnace control extends oscillator tube life
- More efficient combustion of a wider variety of samples while reducing dust and splatter
- Automatic combustion tube removal/installation reduces downtime
- Heated dust filter improves sulfur recovery and low level precision



Additional features and benefits

- High-velocity HEPA vacuum system keeps dust and debris contained
- Optional 10- and 60-sample autoloaders available for hours of worry-free operation
- Robotic process loader available for custom process integration



Models

CS844 Carbon/Sulfur Determinator Specification Sheet 209-214-001

C844 Carbon Determinator Specification Sheet 209-214-002

S844 Sulfur Determinator Specification Sheet 209-214-003

Options

Sample Autoloader

Printer

Interfaced Balance Kit

CORNERSTONE® Mobile

Multiple configurations of options are available.

Please contact your local LECO Sales Engineer for more details.

LECO – Your Source for Total Analytical Solutions



ONH Series:

Oxygen / Nitrogen / Hydrogen by fusion

- Oxygen, nitrogen, and hydrogen by inert gas fusion
- State-of-the-art infrared and thermal conductivity detectors with no moving parts and no manual adjustments
- Custom software interface designed specifically for touch-screen operation
- User-friendly CORNERSTONE® brand software



GDS900: Atomic Emission Spectrometers

- Spectral range from 120 to 850 nm
- Continuous profile of concentration/thickness
- Large, dynamic range with concentrations from ppm to 100% by weight
- Short analysis time (minutes)

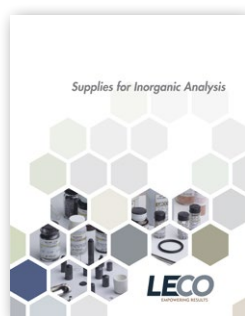

Inorganic consumables

Get the best results from your LECO instrument by using genuine LECO consumables. Visit eu.leco.com for featured items, specials, and ordering information.

A Commitment to Quality and Service



Our global network of sales and support includes over 25 subsidiaries worldwide, and is dedicated to customer service and satisfaction. Our commitment to quality is further underscored with ISO-9001:2015 certification. We conform to CE quality and safety specifications, fully testing instruments at our on-site Compliance Testing Centre.

European Application and Technology Center, Berlin – Germany

Training Classes



Get the most out of your LECO instrument with instrument-specific training classes offered from LECO. Typical classes feature a comprehensive overview of the theory of operation, method development, method optimisation, and proper maintenance for each instrument class. A variety of advanced features are also presented, including quantitation, user library creation, and reporting. Classes also allow for networking opportunities and the ability to learn from other users of our products. Currently available workshops and training courses are listed on our website:

eu.leco.com/events/tradeshows-conferences

eu.leco.com/events/workshops

“Everyone is very knowledgeable (brilliant, if I may say!) and willing to help with any questions/problems. I am amazed at and extremely happy with the high level of service LECO provides.”

LECO Customer and Class Participant

ISO-9001:2015 Q-994 | LECO is a registered trademark of LECO Corporation.
LECO, Cornerstone, and SmartLine are registered trademarks of LECO Corporation.

LECO Corporation
3000 Lakeview Avenue | St. Joseph, MI 49085
Phone: 269-985-5496
info@leco.com | www.leco.com

LECO Europe
eu.leco.com

LECO
EMPOWERING RESULTS